

DWG NO		VCE0500008.02	
Parts List			
ITEM	QTY	PART NUMBER	DESCRIPTION
1	1	CE10-S470859800A	Drive - Belt, 43" w/o motor
2	1	CE10-s470859900a	Drive - Belt, 43" w/o Motor
3	2	CE10-S320678893B	Brkt - RH
4	2	CE10-S320678993B	Brkt - LH
5	2	PN0162868.02	Actr - SMC Rotary (90 degrees)
8	1	2CE0300632.02	Arm - Flap Mounting RH (2EZSB)
9	1	2CE0300633.02	Arm - Flap Mounting LH (2EZSB)
10	2	PT0361014	Bshng - Trantorque 12mm Shaft
11	2	PT0280134.01	Pully - Timng,XL,20T,9mm Bore,3mm key
12	2	MCE0100018.21	Plow - Major Flap
13	2	CE10-s3803447	Motor CE10, 120V, 1PH, RH & LH

NOTE: REPLACE TIMING PULLEY IN DRIVE WITH ITEM 11.

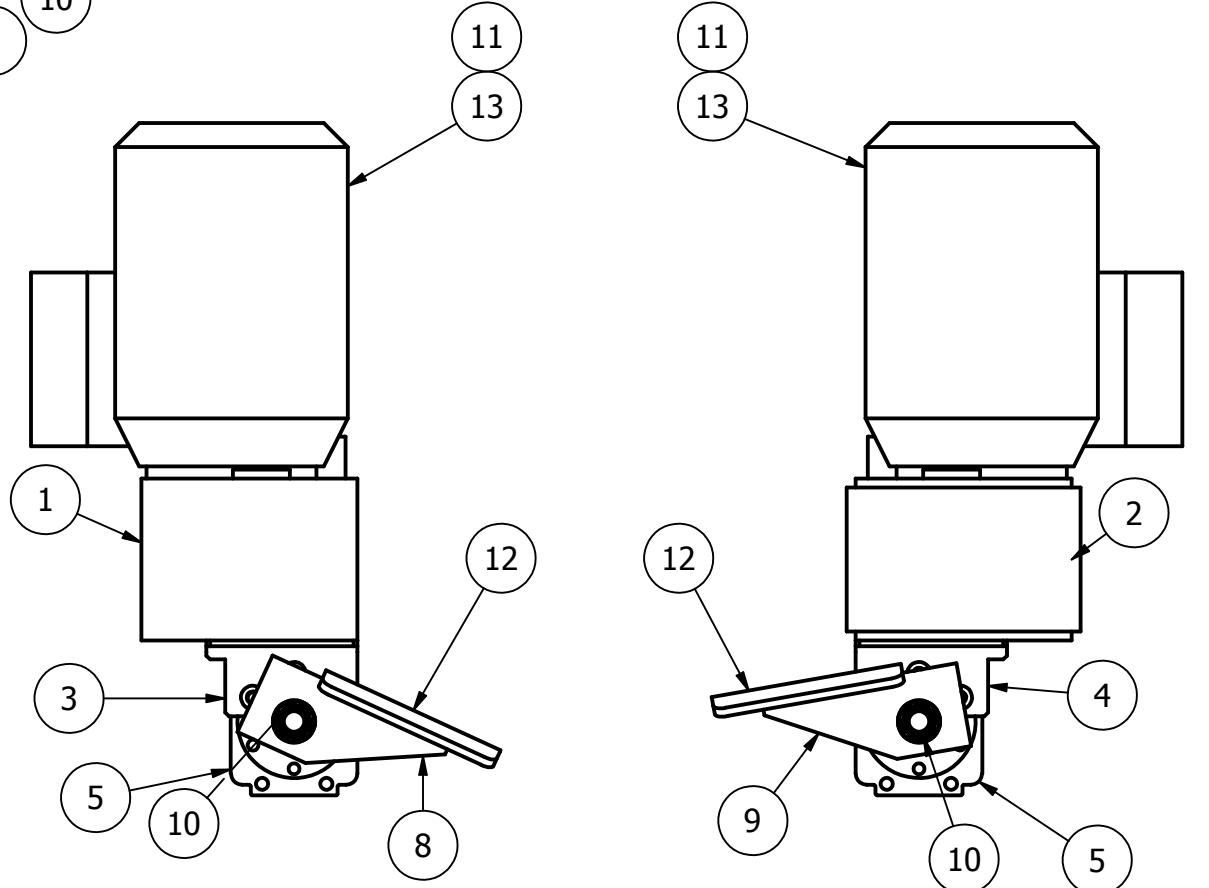

NOTE: UNLESS OTHERWISE SPECIFIED BREAK ALL SHARP EDGES DEVIATIONS FROM THIS DRAWING MUST BE ADDRESSED WITH COMBI PACKAGING SYSTEMS LLC	MATERIAL	FINISH	DESCRIPTION				DWG NO VCE0500008.02	Sheet 1 of 1	REV
	TOLERANCES (UNLESS OTHERWISE SPECIFIED) .000 = ± .003 .00 = ± .010 ANGLES = ± 1/2 FRACTION = ± 1/64	~ NOTE: THIS DRAWING IS NOT TO BE REPRODUCED OR COPIED WITHOUT CONSENT FROM COMBI PACKAGING SYSTEMS	Drive- Side Belt (RH/LH) 2EZSBP						
			DRAWN BY	DRAFT DATE	SCALE				
			JJS	08/04/09	1/4				
			CHECKED BY	CHECK DATE	SIZE				
					B				