

DWG NO TB10500345.01

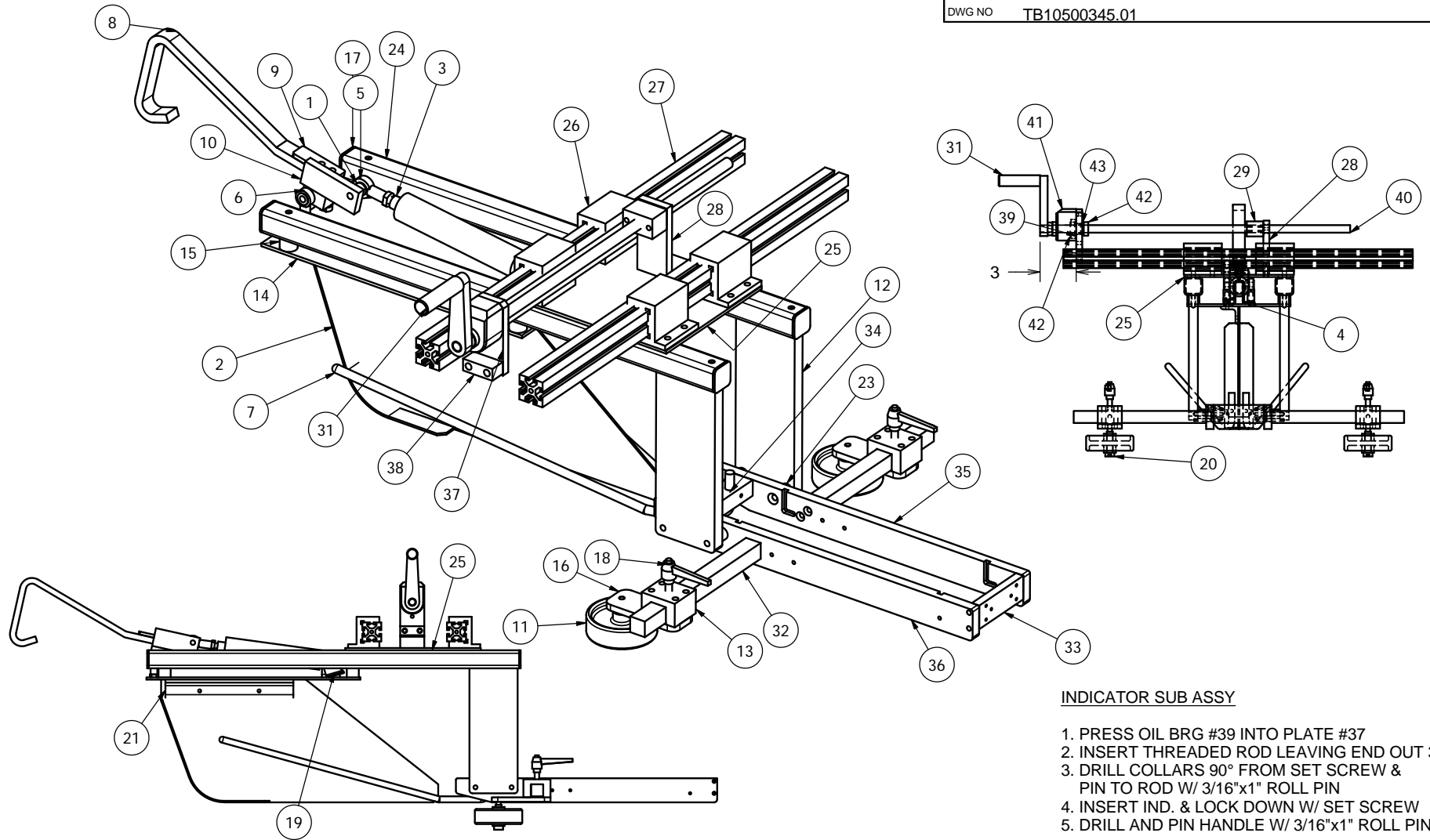

INDICATOR SUB ASSY

1. PRESS OIL BRG #39 INTO PLATE #37
2. INSERT THREADED ROD LEAVING END OUT 3"
3. DRILL COLLARS 90° FROM SET SCREW & PIN TO ROD W/ 3/16"x1" ROLL PIN
4. INSERT IND. & LOCK DOWN W/ SET SCREW
5. DRILL AND PIN HANDLE W/ 3/16"x1" ROLL PIN

<p>MATERIAL SEE B/M</p> <p>TOLERANCES (UNLESS OTHERWISE SPECIFIED) .000 = ± .003 .00 = ± .010 ANGLES = ± 1/2 FRACTION = ± 1/64</p>	<p>FINISH -</p> <p>NOTE: THIS DRAWING IS NOT TO BE REPRODUCED OR COPIED WITHOUT CONSENT FROM COMBI PACKAGING SYSTEMS</p>	<p>DESCRIPTION UPPER 3M 2" 0-LINE 2007</p> <p>DRAWN BY sbeatty</p> <p>CHECKED BY</p>	<p>DRAFT DATE 5/21/2007</p> <p>CHECK DATE</p>	<p>SCALE 3/16:1</p> <p>SIZE B</p>	<p>Combi PACKAGING SYSTEMS LLC</p> <p>DWG NO TB10500345.01</p>
--	---	---	---	---	---