

NOTE: SEE SUB ASSY (1) PROCEDURE:

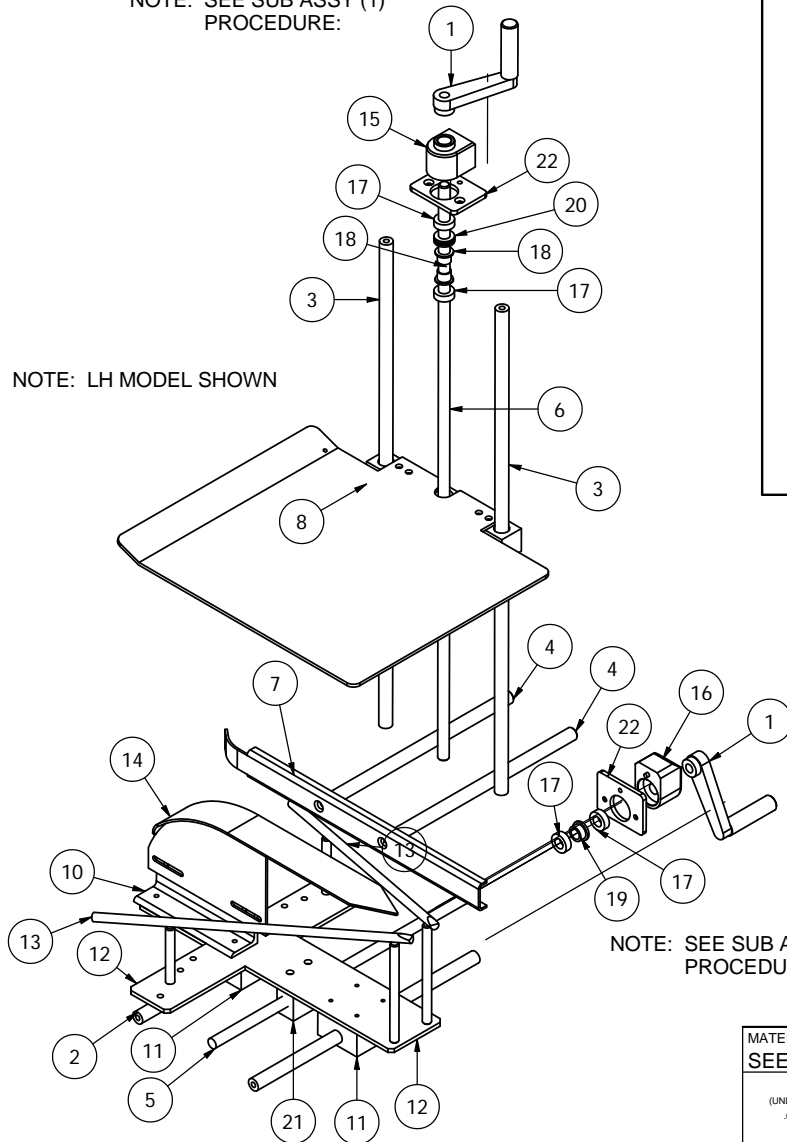

NOTE: LH MODEL SHOWN

NOTE: SEE SUB ASSY (2) PROCEDURE:

SUB ASSY (1) PROCEDURE:

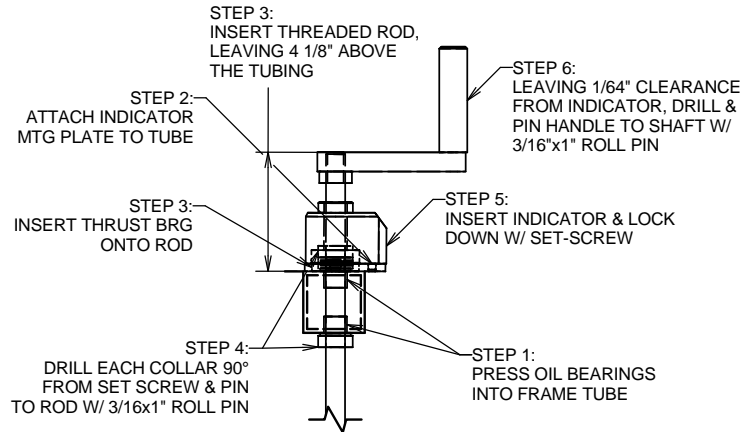

SUB ASSY (2) PROCEDURE:

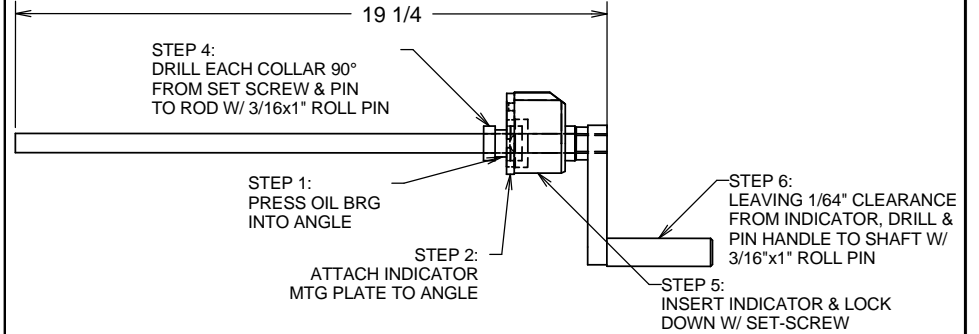

MATERIAL SEE BOM	FINISH SEE BOM	DESCRIPTION PLOW - E2500 W/ INDICATORS					
		DRAWN BY CAZ	DRAFT DATE 3/15/2007	SCALE 3:20			
<small>TOLERANCES (UNLESS OTHERWISE SPECIFIED) .000 ± .003 .00 ± .010 ANGLES ± 1/2 FRACTION ± 1/64</small>		<small>THIS DRAWING IS NOT TO BE REPRODUCED OR COPIED WITHOUT CONSENT FROM COMBI PACKAGING SYSTEMS</small>		CHECKED BY	CHECK DATE	SIZE B	DWG NO 2CE0500274.17